

Creo Parametric 2.0 for SolidWorks Users

Overview

Course Code	TRN-4000-T
Course Length	3 Days

In this course, you will learn about core modeling skills. This comprehensive, hands-on course is specifically designed for existing SolidWorks users who want to become proficient with Creo Parametric as quickly as possible. Topics include understanding the interface and basic Creo Parametric concepts, selecting and editing, sketching tools, and basic feature, part, and assembly creation. The course also includes a comprehensive design project that enables you to practice your new skills by creating realistic parts. After completing the course, you will be well prepared to work effectively on product design projects using Creo Parametric.

At the end of each module, you will complete a set of review questions to reinforce critical topics from that module. At the end of the course, you will complete a course assessment in Pro/FICIENCY intended to evaluate your understanding of the course as a whole.

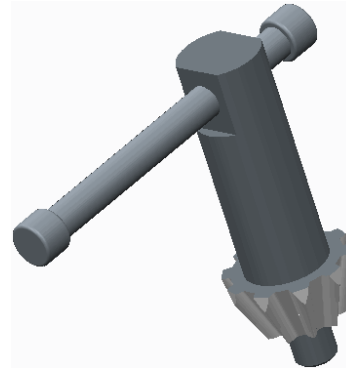

Course Objectives

- Learn the basic Creo Parametric modeling process
- Learn how to use the Creo Parametric interface
- Select and edit geometry, features, and models
- Sketch geometry and use tools
- Create sketches for features
- Create extrudes, revolves, and profile ribs
- Utilize internal sketches
- Create sweeps and blends
- Create holes, shells, and drafts
- Create rounds and chamfers
- Assemble with constraints
- Lay out drawings and create views
- Create drawing annotations
- Investigate parent/child relationships
- Resolve failures and seek help
- Complete a comprehensive design project

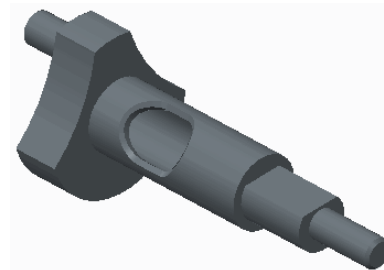

Prerequisites

- Knowledge of SolidWorks, including an understanding of solid modeling, feature-based, parametric, and associative concepts

Audience

- This course is intended for product designers, drafters, and industrial/conceptual designers. People in related roles can also benefit from taking this course.
-

Agenda

Day 1

Module	1	Introduction to the Creo Parametric Basic Modeling Process
Module	2	Using the Creo Parametric Interface
Module	3	Editing Geometry, Features, and Models
Module	4	Sketcher Geometry and Tools

Day 2

Module	5	Creating Extrudes, Revolves, and Ribs
Module	6	Creating Sweeps and Blends
Module	7	Creating Holes, Shells, and Draft
Module	8	Creating Rounds and Chamfers

Day 3

Module	9	Project I
Module	10	Assembling with Constraints
Module	11	Introduction to Drawings
Module	12	Resolving Failures and Seeking Help

Course Content

Module 1. Introduction to the Creo Parametric Basic Modeling Process

- i. Creo Parametric Basic Modeling Process

Module 2. Using the Creo Parametric Interface

- i. Understanding the Main Interface
- ii. Setting the Working Directory and Opening and Saving Files
- iii. Understanding the Ribbon Interface
- iv. Customizing the Ribbon Interface
- v. Analyzing Basic 3-D Orientation
- vi. Creating and Managing View Orientations
- vii. Setting Up New Part Models
- viii. Understanding Creo Parametric Basic Controls
- ix. Understanding the Model Tree
- x. Selecting Items using Direct Selection
- xi. Selecting Items using Query Selection
- xii. Using the Search Tool
- xiii. Using the Smart Selection Filter
- xiv. Understanding Selection Filters

Knowledge Check Questions

Module 3. Editing Geometry, Features, and Models

- i. Using Drag Handles and Dimension Dragers
- ii. Understanding Regeneration and Auto Regeneration
- iii. Editing Features
- iv. Editing Features using Edit Definition
- v. Activating and Editing Models
- vi. Deleting and Suppressing Items
- vii. Editing Feature and Component Visibility
- viii. Applying Shape Selection
- ix. Applying Flexible Move using the Dragger
- x. Applying Flexible Move by Dimension

Knowledge Check Questions

Module 4. Sketcher Geometry and Tools

- i. Reviewing Sketcher Theory
 - ii. Modifying the Sketcher Display
 - iii. Utilizing Constraints
 - iv. Sketching with On-the-Fly Constraints
 - v. Sketching Lines
 - vi. Sketching Rectangles and Parallelograms
 - vii. Sketching Circles
-

- viii. Using Geometry Tools within Sketcher
- ix. Manipulating Sketches within Sketcher
- x. Dimensioning Entities within Sketcher
- xi. Modifying Dimensions within Sketcher
- xii. Sketcher Conflicts
- xiii. Creating Sketches ('Sketch' Feature)
- xiv. Specifying and Manipulating the Sketch Setup
- xv. Utilizing Sketch References

Knowledge Check Questions

Module 5. Creating Extrudes, Revolves, and Ribs

- i. Creating Solid Extrude Features
- ii. Adding Taper to Extrude Features
- iii. Common Dashboard Options Extrude Depth
- iv. Common Dashboard Options Feature Direction
- v. Common Dashboard Options Thicken Sketch
- vi. Creating Solid Revolve Features
- vii. Common Dashboard Options Revolve Angle
- viii. Automatically Adding and Removing Material
- ix. Creating Profile Rib Features
- x. Creating Internal Sketches

Knowledge Check Questions

Module 6. Creating Sweeps and Blends

- i. Creating Sweeps with Open Trajectories
- ii. Creating Sweeps with Closed Trajectories
- iii. Analyzing Sweep Feature Attributes
- iv. Creating Blends by Selecting Parallel Sections
- v. Creating Blends by Sketching Sections
- vi. Analyzing Blend Options

Knowledge Check Questions

Module 7. Creating Holes, Shells, and Draft

- i. Common Dashboard Options Hole Depth
- ii. Creating Coaxial Holes
- iii. Creating Linear Holes
- iv. Creating Shell Features
- v. Creating Draft Features
- vi. Creating Basic Split Drafts

Knowledge Check Questions

Module 8. Creating Rounds and Chamfers

- i. Creating Rounds Theory
 - ii. Creating Rounds by Selecting Edges
-

- iii. Creating Rounds by Selecting a Surface and Edge
- iv. Creating Full Rounds
- v. Creating Round Sets
- vi. Creating Chamfer Sets

Knowledge Check Questions

Module 9. Project I

- i. The Air Circulator
- ii. Piston Assembly Components
- iii. Crankshaft, Engine Block, Impeller, and Impeller Housing
- iv. The Frame and Bolt

Module 10. Assembling with Constraints

- i. Understanding Assembly Theory
- ii. Creating New Assembly Models
- iii. Understanding Constraint Theory
- iv. Understanding Assembly Constraint Status
- v. Assembling Components using the Default Constraint
- vi. Orienting Components
- vii. Creating Coincident Constraints using Geometry
- viii. Assembling using Automatic

Knowledge Check Questions

Module 11. Introduction to Drawings

- i. Drawing Development Process
- ii. Analyzing Drawing Concepts and Theory
- iii. Analyzing Basic 2-D Orientation
- iv. Creating New Drawings and Applying Formats
- v. Creating and Orienting General Views
- vi. Adding Drawing Models
- vii. Creating Projection Views
- viii. Analyzing Annotation Concepts and Types
- ix. Showing, Erasing, and Deleting Annotations
- x. Cleaning Up Dimensions
- xi. Manipulating Dimensions

Knowledge Check Questions

Module 12. Resolving Failures and Seeking Help

- i. Understanding Parent Child Relationships
 - ii. Viewing Part Parent Child Information
 - iii. Reordering Features
 - iv. Inserting Features
 - v. Understanding and Identifying Failures
 - vi. Analyzing Geometry Failures
-

vii. Analyzing Missing Part Reference Failures

viii. Using Creo Parametric Help

Knowledge Check Questions
