

## PRODUCT SPEC SHEET

# XTREME 8K

The largest size production-grade DLP 3D printer in the world\*\* for high-volume production of end-use parts.

The Xtreme 8K makes volume production of 3D-printed parts a reality, with the ability to print thousands of parts per day. With wide material compatibility, including hard plastics, high-temperature plastics, elastomers and rubbers, the Xtreme 8K enables the production of the broadest possible range of parts.

The Xtreme 8K leverages long-chain polymer chemistry to create fully-isotropic, stable, end-use parts, and features a heated vat, allowing users to process highly viscous and solid materials at room temperatures.

**MACHINE PROPERTIES\***

Build Envelope (L x W x H)	450 x 371 x 399 mm (17.72 x 14.61 x 15.71 in)
Native XY Resolution	150 µm
Enhanced XY Resolution	100 µm
Z Resolution	100–175 µm
Warranty	1 year back to factory included
Footprint (L x W x H)	1,420 x 1,052 x 2,083 mm (55.9 x 41.42 x 82 in)
Weight	907.18 kg (2,000 lbs.)
Electrical Requirements	220 VAC, Three Phase, 20A

**SYSTEM PROPERTIES**

- Produce everything from concept models to functional parts
- Connect directly to a PC workstation or be integrated into a network for pre-processing of job files and remote monitoring
- The stand-alone PC allows for working independently from preprocessing workstation
- Highest resolution DLP printer with industrial UV engine

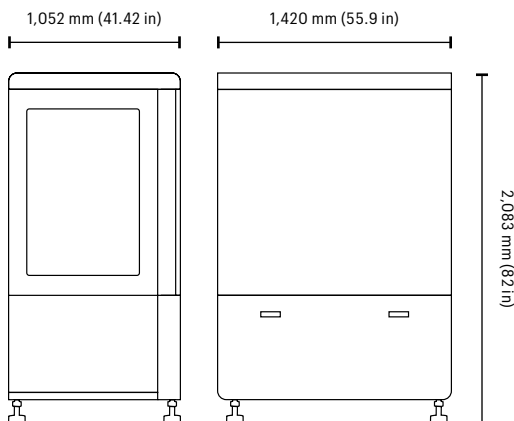

\*Specifications are subject to change without notice.

\*\*Xtreme 8K offers the largest build area among commercially-available, production-grade DLP printers